

nanit

User Guide

TABLE OF CONTENTS///

- Safety -----3
- Camera & Floor Stand -----4
- In the Box -----5
- Assembly -----6
- Limited Warranty-----8

Learn More:

Go to nanit.com

Questions about installation:

Go to nanit.com/installnanit for installation videos.

Need help?

Contact us at support.nanit.com

FCC and Industry Canada Compliance information:

Go to nanit.com/legal/compliance

SAFETY///

- Strangulation Hazard—Children have STRANGLED in cords. NEVER attempt to use cord without the protective covering. Check protective covering before each use to ensure that the cord is not exposed to your child. Immediately discontinue use if protective covering is damaged or broken.
- This device is designed to be used behind a standard crib and against the wall only.
- Adult assembly is required. Keep small parts away from children when assembling.
- This product cannot replace adult supervision. Ensure your child's health by checking on him/her regularly.
- This device is designed for indoor use only.
- This product is not a toy. Do not allow children to play with it.
- Use only the AC power supply included with your Nanit.

NANIT CAMERA & FLOOR STAND///

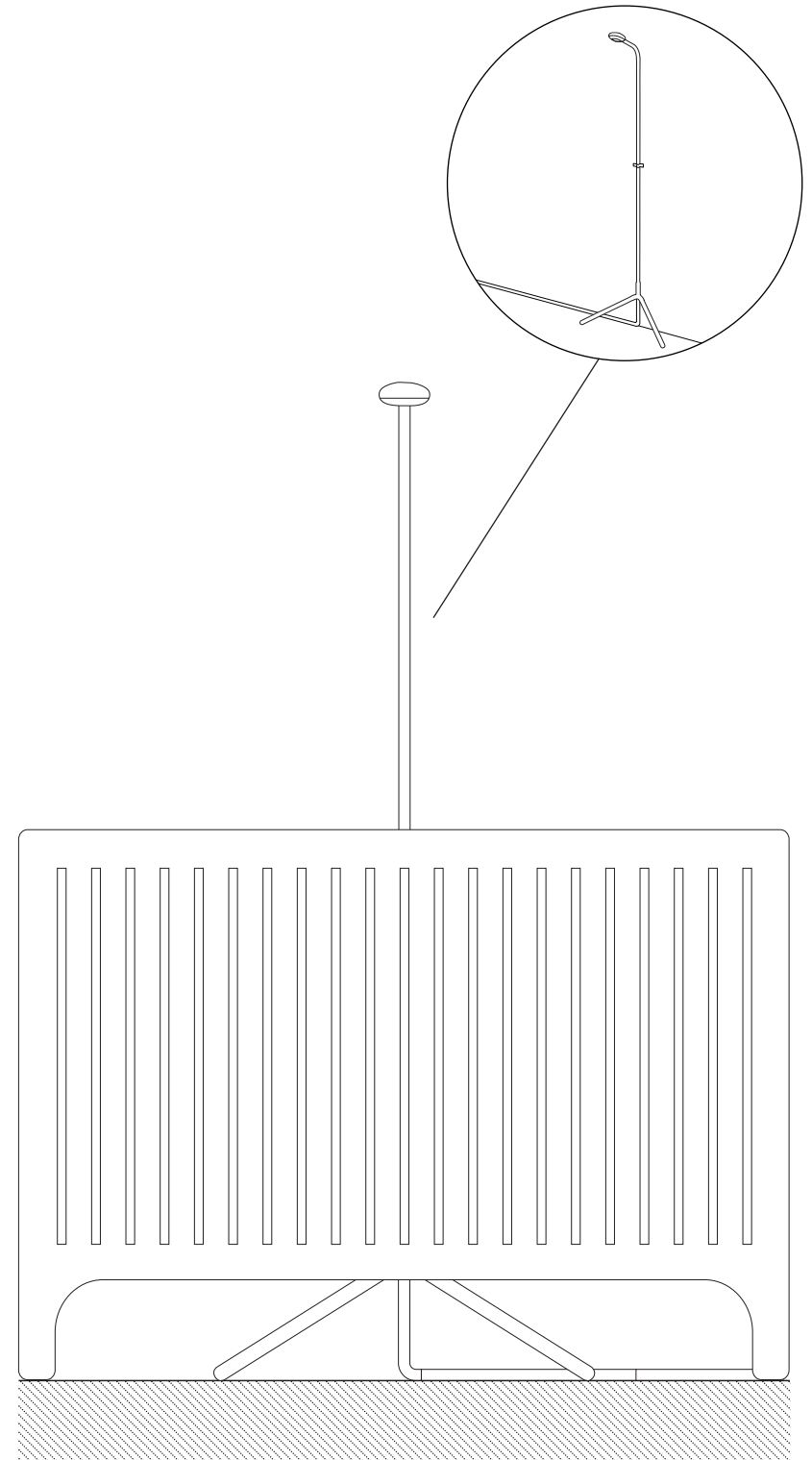

IN THE BOX///

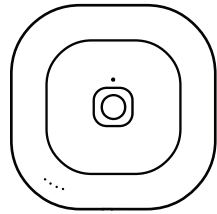

Camera

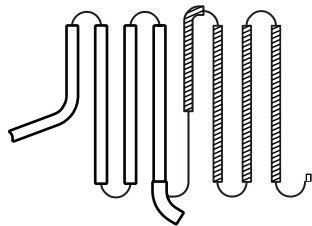

4 Floor Stand Components and
4 Cable Management Channels

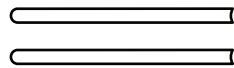

2 Floor Stand Legs



Power Adapter



U-Clip and 2 Wall Screws

ASSEMBLY///

1

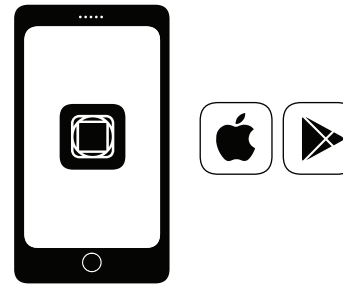

Download the free Nanit app and create an account.

2

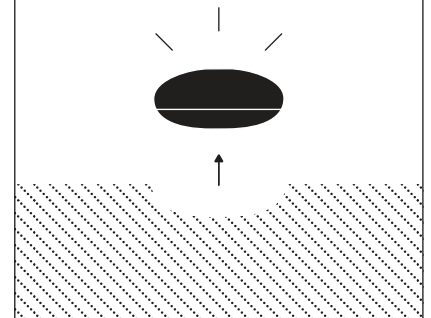

Remove camera from box.

3

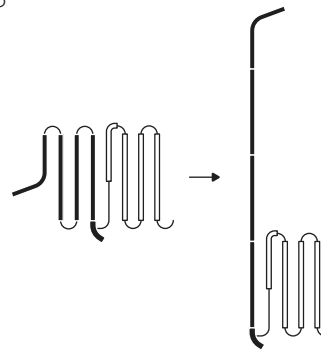

Assemble stand, top to bottom.

4

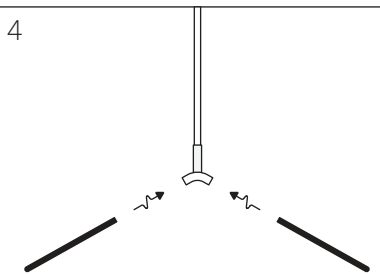

Screw legs to stand.

5

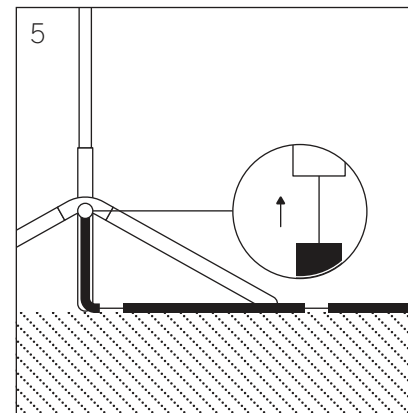

Connect L-shape channel to stand.

6

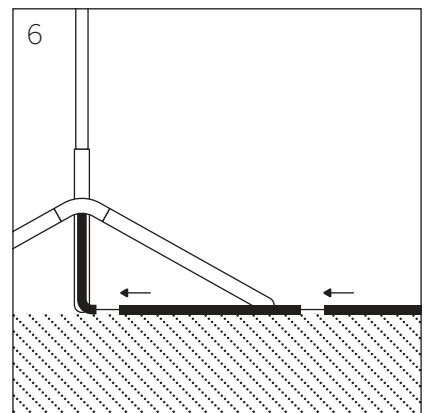

Connect cable management channels.

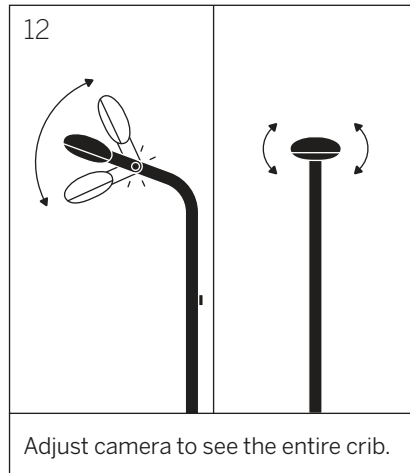
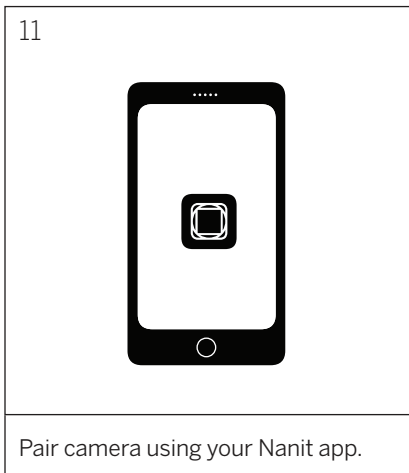
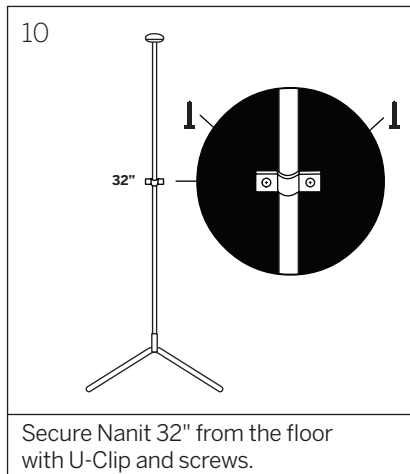
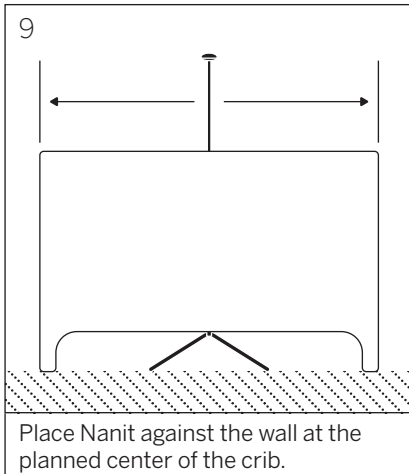
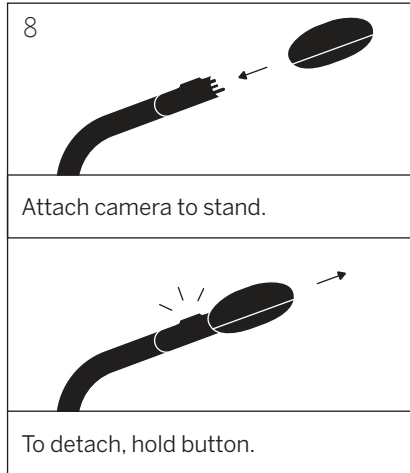
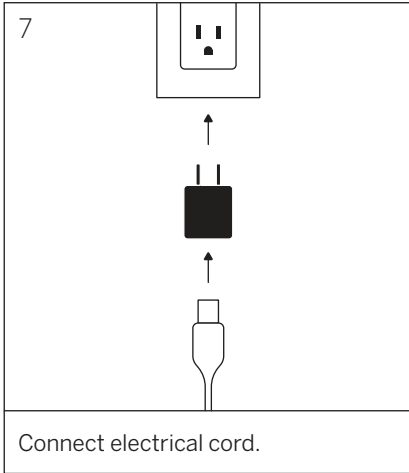

LIMITED WARRANTY///

THIS LIMITED WARRANTY CONTAINS IMPORTANT INFORMATION ABOUT YOUR RIGHTS AND OBLIGATIONS, AS WELL AS LIMITATIONS AND EXCLUSIONS THAT MAY APPLY TO YOU.

1. WHAT THIS LIMITED WARRANTY COVERS; PERIOD OF COVERAGE.

Udisense, Inc. DBA: Nanit ("Nanit"), located at 244 Fifth Avenue, Suite #2702 New York, NY 10001, warrants to the owner of the enclosed product that the product contained in this box ("Product") will be free from defects in materials and workmanship for a period of one (1) year from the date of delivery following the original retail purchase (the "Warranty Period"). If the Product fails to conform to this Limited Warranty during the Warranty Period, Nanit will, at its sole discretion, either (a) repair or replace any defective Product or component; or (b) accept the return of the Product and refund the money actually paid by the original purchaser for the Product. Repair or replacement may be made with a new or refurbished product or components, at Nanit's sole discretion. If the Product or a component incorporated within it is no longer available, Nanit may, at Nanit's sole discretion, replace the Product with a similar product of similar function. This is your sole and exclusive remedy for breach of this Limited Warranty. Any Product that has either been repaired or replaced under this Limited Warranty will be covered by the terms of this Limited Warranty for the longer of (a) ninety (90) days from the date of delivery of the repaired Product or replacement Product, or (b) the remaining Warranty Period. This Limited Warranty is transferable from the original purchaser to subsequent owners, but the Warranty Period will not be extended in duration or expanded in coverage for any such transfer.

2. TOTAL SATISFACTION RETURN POLICY.

If you are the original purchaser of the Product and you are not satisfied with this Product for any reason, you may return it in its original condition within thirty (30) days of the original purchase and receive a full refund.

3. WARRANTY CONDITIONS; HOW TO GET SERVICE IF YOU WANT TO CLAIM UNDER THIS LIMITED WARRANTY.

Before making a claim under this Limited Warranty, the owner of the Product must (a) notify Nanit of the intention to claim by visiting support.nanit.com during the Warranty Period and providing a description of the alleged failure, and (b) comply with Nanit's return shipping instructions. Nanit will have no warranty obligations with respect to a returned Product if it determines, in its reasonable discretion after examination of the returned Product, that the Product is an Ineligible Product (defined below).

4. WHAT THIS LIMITED WARRANTY DOES NOT COVER.

This Limited Warranty does not cover the following (collectively "Ineligible Products"): Products marked as "sample" or "Not for Sale", or sold "AS IS"; or Products that have been subject to: (a) modifications, alterations, tampering, or improper maintenance or repairs; (b) handling, storage installation, testing, or use not in accordance with the Terms of Service or other instructions provided by Nanit; (c) abuse or misuse of the Product; (d) breakdowns, fluctuations, or interruptions in electric power or the telecommunications network; or (e) Acts of God, including but not limited to lightning, flood, tornado, earthquake, or hurricane. This Limited Warranty does not cover consumable parts, including batteries, unless damage is due to defects in materials or workmanship of the Product, or software (even if packaged or sold with the product). Nanit recommends that you use only authorized service providers for maintenance or repair. Unauthorized use of the Product or software can impair the Product's performance and may invalidate this Limited Warranty. This Limited Warranty does not apply to anything other than the Products, including any software, even if packaged or sold with the Products. Software distributed by Nanit (including, but not limited to system software) is not covered under this Limited Warranty. Refer to the licensing agreement accompanying the software for details of your rights with respect to its use. Nanit does not warrant that the operation of the product will be uninterrupted or error-free.

5. NOT A MEDICAL DEVICE.

The services and the products are not intended to be used as a medical device and the products are not medical devices. Furthermore, the services and the products are neither regulated nor approved by the U.S. Food and drug administration, and are not designed to detect or prevent causes of any medical condition. The services are not a substitute for medical care or adult supervision.

You acknowledge, understand and agree that your use of the services and the products is entirely at your own risk.

6. DISCLAIMER OF WARRANTIES.

Except as stated above in this limited warranty, and to the maximum extent permitted by applicable law, Nanit disclaims all express, implied, and statutory warranties and conditions with respect to the product, including the implied warranties of merchantability, fitness for a particular purpose and non-infringement. To the maximum extent permitted by applicable law, Nanit also limits the duration of any applicable implied warranties or conditions to the duration of this limited warranty.

7. LIMITATION OF DAMAGES.

In addition to the above warranty disclaimers, in no event will Nanit be liable for any consequential, incidental, exemplary, or special damages, including any damages for lost data or lost profits, arising from or relating to this limited warranty or the product, and Nanit's total cumulative liability arising from or related to this limited warranty or the product will not exceed the amount actually paid for the product by the original purchaser.

8. LIMITATION OF LIABILITY.

The Nanit online services ("services") provide you information ("product information") regarding your Nanit products or other peripherals connected to your products ("product peripherals"). The type of product peripherals that may be connected to your product may change from time to time. Without limiting the generality of the disclaimers above, all product information is provided for your convenience, "as is", and "as available". Nanit does not represent, warrant, or guarantee that product information will be available, accurate, or reliable or that product information or use of the services or product will provide safety in your home. You use all product information, the services, and the product at your own discretion and risk. You will be solely responsible for (and Nanit disclaims) any and all loss, liability, or damages, including to your wiring, fixtures, electricity, home, product, product peripherals, computer, mobile device, and all other items and pets in your home, resulting from your use of the product information, services, or product. Product information provided by the services is not intended as a substitute for direct means of obtaining the information. For example, a notification provided through the service is not intended as a substitute for audible and visible indications in the home and on the product, nor for a parent checking on the child.

9. YOUR RIGHTS AND THIS LIMITED WARRANTY.

This Limited Warranty gives you specific legal rights. You may also have other legal rights that vary by state, province, or jurisdiction. Likewise, some of the limitations in this Limited Warranty may not apply in certain states. The terms of this Limited Warranty will apply to the extent permitted by applicable law. For a full description of your legal rights you should refer to the laws applicable in your jurisdiction and you may wish to contact a relevant consumer advisory service.

